

*Authors: Carlos Martinez, Dave Sorlien, Raymond Goodrich, Lance Chandler, Doug Magnuson*

## Introduction

Common multiple cell configurations for Lilon cells in battery packs consist of three or four cells in series, with one or more cells in parallel. This combination gives both the voltage and power necessary for Portable Computer, medical, test and industrial applications. While these configurations are common today, they may not be as efficient as they could be. The reason for this is that any capacity mismatch between cells in a series connection of cells results in a reduction of overall pack capacity.

There are two kinds of mismatch in the pack, State-of-Charge (SOC) and capacity/energy (C/E) mismatch. Each problem limits the pack capacity (mAh) to the capacity of the weakest cell. It is important to recognize that the cell mismatch results more from limitations in process control and inspection than from variations inherent in the Lithium Ion chemistry. As such, these types of cell to cell variation more likely occur in Lilon prismatic cells, due to more extreme mechanical stresses, and in Lilon Polymer, due to the newer processes involved.

The use of cell balancing can improve the performance of series connected Lilon Cells by addressing both State-of-Charge and Capacity/Energy issues. SOC mismatch can be remedied by balancing the cell during an initial conditioning period and subsequently only during the charge phase. C/E mismatch can be remedied by balancing during both charge and discharge periods. Even though the defect level for a given cell manufacturer may be very low, the extra confidence that a pack will not be returned, because of an early end of life, may be well worth the extra effort. It provides another level of quality assurance.

To provide some insight into the issues, this article discusses cell balancing, offers some guidelines for implementing cell balancing, and provides some actual results achieved through cell balancing techniques.

## Definition of Cell Balancing

For portable systems requiring 6V or more of operating voltage, battery packs utilize battery cells connected in series. A series connection results in a pack voltage equal to the sum of the cell voltages. For portable computers (PCs), the battery pack typically has 3 or 4 cells in series with nominal voltages of 10.8V or 14.4V. In the majority of these applications, the system requires more energy than is provided by a single series string of battery cells. Since the largest cell typically available (i.e. 18650) has a capacity 2000mAh, a PC requiring 50–60 Whr. of energy (5000–6000 mAh) requires three cells connected in parallel to each of the series cells.

Cell balancing is defined as the application of differential currents to individual cells (or combinations of cells) in a series string. Normally, of course, cells in a series string receive identical currents. A battery pack requires additional components and circuitry to achieve cell balancing.

Cell balancing is only considered when multiple cells in a battery pack are connected in series and usually when there are three or more series cells. Battery pack cells are balanced when all the cells in the battery pack meet two conditions.

1. If all cells have the same capacity, then they are balanced when they have the same relative State of Charge (SOC.) SOC is usually expressed in terms percent of rated capacity. In this case, the Open Circuit Voltage (OCV) is a good measure of the SOC. If, in an out of balance pack, all cells can be differentially charged to full capacity (balanced) then they will subsequently cycle normally without any additional adjustments. This is mostly a one shot fix. The customer usually has instructions with a new pack to provide an overnight conditioning on the first cycle. Overnight conditioning typically consists of one complete discharge, followed by one complete charge cycle. Conditioning the pack overnight reduces the demands on the cell balance circuitry by minimizing the load and maximizing the charge time.
2. If the cells have different capacities, they are also considered balanced when the SOC is the same. But, since SOC is a relative measure, the absolute amount of capacity for each cell is different. To keep the cells with different capacities at the same SOC, cell balancing must provide differential amounts of current to cells in the series string during both charge and discharge on every cycle. Since charge and discharge cycles times can be shorter than the initial charge time, this process demands higher currents. Therefore, it is a much more demanding issue.

When the cells in the battery pack are not balanced, the battery pack has less available capacity. The capacity of the weakest cell in the series string determines the overall pack capacity. In an unbalanced battery pack, during charging, one or more cells will reach the maximum charge level before the rest of the cells in the series string. During discharge the cells that are not fully charged will be depleted before the other cells in the string, causing early undervoltage shutdown of the pack.

Manufactured cell capacities are usually matched within 3%. If less than optimal Li-ion cells are introduced in to a series string pack or cells have been on the shelf for a long period prior to pack assembly, a 150mV difference at full charge is possible. This could result in a 13-18% reduction in battery pack capacity.

### SOC Balancing

SOC balancing is used when all cells in the pack have the same capacity. As such, cells are considered balanced when:

$$SOC_1 = SOC_2 = SOC_3 = \dots SOC_{CELLN}$$

Looking at an individual cell, the state of charge is defined as:

$$SOC = \frac{C}{C_{TOTAL(\text{percent})}}$$

The capacity of a cell is defined as:

$$C = (i \times t)\text{mAh}$$

To determine the capacity of a cell (C), the cell is fully discharged to its minimum operating voltage, then charged, while measuring the current and the time, until it reaches an open circuit voltage (OCV) of 4.20V. With perfectly performing cells, the SOC in this condition is 100%. A unique open circuit voltage (OCV) is also associated with the 50% SOC and usually known as  $V_{MID}$ . A typical  $V_{MID}$  is 3.67V.

The definition of balanced cells is strictly true, even if the cells have different capacities. In order to charge cells with different capacities to the same SOC requires that some cells be charged or discharged more or less than others in absolute terms. This requires the use of a differential current (cell balancing technique) and is termed Capacity/ Energy Maximization.

### Capacity/Energy Maximization

The term Capacity/Energy Maximization refers to the setting of all series cells in a pack to the same SOC even though they have different capacities. Managing the SOC at all times, maximizes the energy output of the pack.

To maximize energy output, the cells must all be fully charged. That is, the SOC of all cells is 100%. If the cells have different capacities, some cells will charge and discharge more than others. Consider the case where, in a 3 cell series stack,  $C_1 > C_2 = C_3$ . The only way to balance the pack is to apply a differential charging current (cell balancing) to the cell with higher capacity ( $C_1$ ). The same has to be done as the pack discharges. If not done, then the total pack capacity diminishes because the pack discharge shuts off when the cell with the least capacity reaches its cutoff voltage. More important, in this case, is that the weakest cell reaches cutoff while capacity remains in the other cells. Over time, this degrades the weakest cells faster than the others, thus accelerating capacity loss over many charge/discharge cycles.

By matching the voltage of each cell in the string on the way down, more current is drawn from the higher capacity cells. During discharge this process requires that there is some

additional voltage loss while balancing, but in the end, when all cells arrive at zero SOC, there is an increase in the total energy extracted from the pack over time.

### Cell Manufacturing State of the Art with respect to Balancing

Li-ion cylindrical cells today generally have very good quality control, with cell capacity matched to  $\pm 3$  percent. The input capacity is essentially exact and being within a few milliampereseconds. So the absolute amount of charge (mAh) is initially exact and the SOC is within a few percent.

### Liion Self-discharge and the Need for SOC Matching

Liion Chemistry does not create cell imbalance and has no mechanism for reversible self discharge. On the other hand, there is a process by which the cell chemistry stabilizes and creates what is known as irreversible loss. Most of this loss is experienced inside the factory. Since these cells are rejected in the factory, gross errors are not observed by the user. However, a small amount of irreversible loss can be experienced in high temperature discharge and over long periods of time at room temperature. The maximum amount tends to be less than 10 percent and all cells stored or used together will experience this effect at the same rate. So cell imbalance is not created by this mechanism. There is a small reversible loss associated with this irreversible loss but it is proportional. The amount of reversible loss created in the factory is recharged before capacity sorting. Therefore, loss in the field is very small and consistent from cell to cell. Again it is no cause for cell imbalance.

Another source of pack cell imbalance occurs when cells remain on the shelf for long periods of time prior to assembly. This is compounded if cells from different manufacturing lots are mixed within a pack. In this case, cells with varying reversible losses will have had time to accumulate significant differences after capacity sorting operations, but before pack assembly. Even after assembly, imbalances can develop over time within the pack, if cells within a pack vary significantly – especially if the pack remains “on the shelf” for a significant period.

### Soft Shorts

Soft shorts are the primary cause of cell imbalance in some cells. Due to tiny imperfections in cell construction the cell can have very high resistance shorts on the order of 40,000 $\Omega$  or more. The self discharge rate due to this higher resistance is on the order of 0.1 milliamperes or 3% per month. Most cells do not have this condition and can hold much of their capacity for years. Some cells which meet specifications when they leave the factory may sometimes develop this condition later. This is strictly an electromechanical condition. Used in a single cell pack, this cell can just be recharged and shows no capacity loss. But, in a series pack, a cell with soft shorts could lose 3% per

month, while another cell loses none at all. This differential SOC in the pack reduces overall pack capacity. Without a corresponding capacity degradation, a conditioning operation primarily needs to be done once before the device is used, then occasionally again, if put in to storage. This recovers the initial capacity loss, then a less aggressive balancing during each charge cycle prevents a return of any mismatches. This continuous adjustment is typically so tiny as to be imperceptible to the user. After the initial operation, balancing on discharge is not needed.

**EXAMPLE:**

This example is based on actual data collected.

Consider a two cell series pack. Cell #1 has discharged 3% per month for three months from 40% SOC to 31% SOC. The other cell #2 has no soft shorts and remains at 40% SOC. When charged, cell #2 reaches 100% SOC when cell #1 is at 91%. When discharged, cell #1 is at 0% SOC and cell #2 remains at 9%. This represents a 9% loss for the pack.

If the cells were balanced by applying a differential current to cell #1 then both cells and the pack would provide full capacity. The charge loss of cell # 1 did not degrade its capacity. See Figure 1a and 1b.

**Capacity Degradation**

Capacity degradation is a loss of cell capacity due to manufacturing or process variations. The likelihood of production cells containing these anomalies is quite low and cells made at the same time generally perform the same. As a result, the vast majority of cells will not tend to become unbalanced in a pack situation. However, a small number of random imperfections can occur in cells. When this is

coupled with a wide variation in pack operating temperature, the result is that some cells can degrade faster than others. As an example, consider a pack that covers a considerable area of a PC. The pack is large enough that some areas of the pack are in close proximity to the power supplies or CPU. These localized areas are subjected to more heat than cells in other parts of the pack. This problem may be remedied with cell balancing, but the balancing must be done during both charge and discharge in a process called capacity/energy maximization. This process is difficult to implement in practice and is not intuitively obvious. For these reasons, further discussion of C/E maximization are left to a subsequent study.

**Keeping Cells Balanced**

Monitoring cell voltages and temperature allows the tracking of cell voltage variations. When a cell voltage variation is larger than 10mV (or some other value) circuitry enables a balancing routine that matches the voltages of the cells in battery pack.

The balancing routine operates by “shunting” current around the cell that needs balancing (the highest voltage cell). Typically a series combination of a power transistor and current limiting resistor connect parallel to each series cell in the pack to control the balancing. During a charge operation, turning on the power transistor diverts part of the charge current around the cell so it will charge at a slower rate than the other cells in the pack. During discharge, turning on the power transistor increases the effective load on the cell so it discharges faster than the rest of the cells in the pack. Thus it is possible to balance the cells during charge mode, or discharge mode, or both.

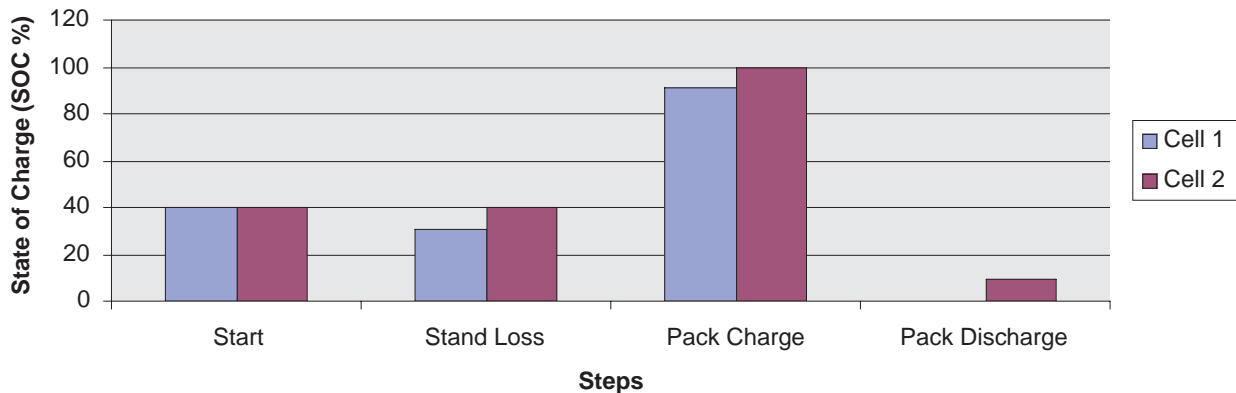

FIGURE 1A. PACK CAPACITY LOSS DUE TO SOFT SORT – NO BALANCING

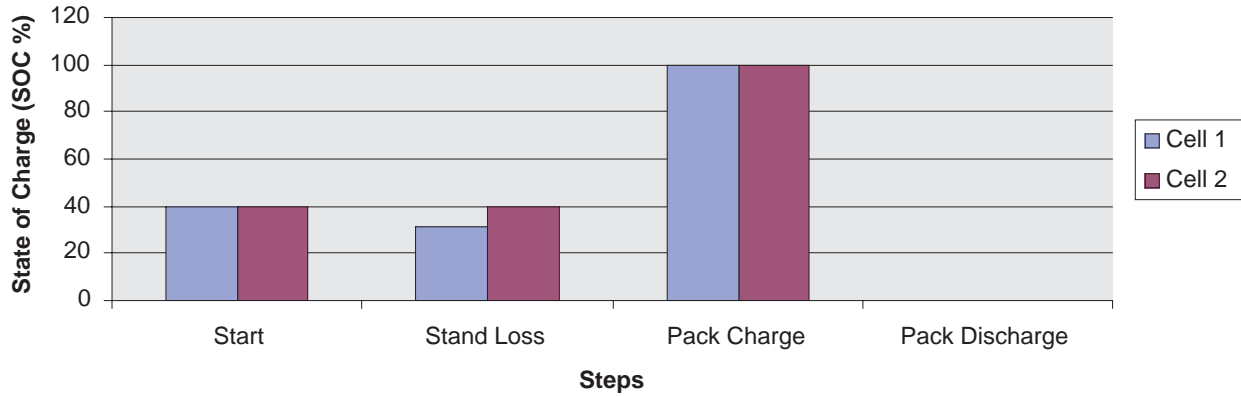

FIGURE 1B. PACK CAPACITY LOSS DUE TO SOFT SORT – BALANCING

**Power Dissipation Requirements Using an External Transistor**

When choosing components for the cell balancing circuit, care is needed in the selection of power transistor and current limiting resistor to keep the currents within reasonable limits. If balancing current is too high, power dissipation can be considerable. The result can be battery pack heating or component stress. If balancing current is too low, balancing takes too long or requires too many cycles to return a benefit. The result is ineffective or non-existent cell balancing.

Three considerations determine the rate of current flow. Amount of imbalance, time available, and cell capacity.

- A reasonable amount of cell balancing was noted previously as 10 - 20%. For soft short issues this is 3 to 6 months of discharge at 3%/month. For cycle life imbalances this translates to a capacity loss of about 16% at 100 cycles.
- A reasonable time available for cell balancing can be as short as 1 charge/discharge period. For SOC imbalance, the time can extend – up to 18 hours (Note 1). For capacity imbalance, the 1.0 hr is a typical charge time and 2.5 hrs would be considered a minimum discharge time.
- The 18650 is the highest capacity cell at 2000mAh. Usually a maximum of 3 cells connect in parallel. So, the highest required balancing current to correct for a 20% capacity imbalance is:

$$I_{BALANCE} = \frac{20(\text{percent}) \times 2000\text{mAh} \times 3}{1.0\text{hr}} = 1200\text{mA}$$

NOTE:

1. This 18 hour time period is not a single charge time (this is not industry accepted practice,) but is devoted to a conditioning process that consists of at least one discharge and one charge cycle. It could also be many cycles (see section "One Time" SOC Adjustment.)

To achieve this level of balancing, the pack would need to be conditioned overnight. Using a charge time of one hour and

a discharge time of 3 hours, two discharge/charge cycles provides 8 hours of balancing. This requires a balancing current of 150mA. This current is quite high. For example, if the cell is 4V, a cell balancing current of 150mA dissipates 0.6 Watts.

Likely, the best compromise is to use cell balancing currents between 50mA and 150mA and planning a initial balancing operation using multiple cycles.

**Cell Balancing Theory**

The present circuit technique to balance cells is shown in Figure 2.

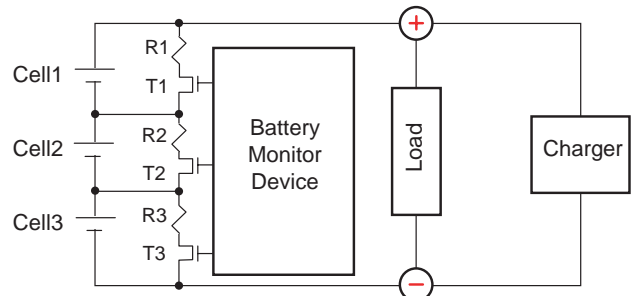
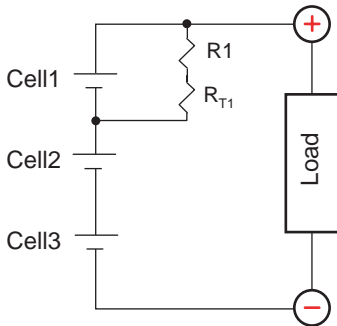

FIGURE 2.

Cells "Cell1" to "Cell3" represent the battery. The balancing circuit is represented by (R1, T1) to (R3, T3). It is assumed that transistors T1 to T3 and resistors R1 to R3 are external to the battery monitor device. It is possible to integrate these components in the battery monitor device, but transistors T1 to T3 will have to scale down due to area and power constraints. Integrating T1 to T3 on chip reduces balancing current to less than 10mA of current, extending the time to balance a mismatched cell. Also, care must be taken to balance only one cell at a time to avoid internal heating in the battery monitor device, which can lead to errors in measurements as the performance of the A/D converter and analog conditioning circuits degrade.

As an example, assume that Cell1 needs balancing. To perform the balance during battery discharge phase, with charger off, transistor T1 turns on while transistors T2 & T3 remain off. The battery cell connection will look as shown in Figure 3.



**FIGURE 3.**

The Thevenin equivalence of the configuration in Figure 3 is shown in Figure 4.

From the Thevenin equivalence it is clear to conclude that the discharge path of Cell1 via transistor T1 does not take away current from Cell2 & Cell3. Thus transistor T1 only discharges Cell1 and similarly transistor T2 only will discharge Cell2 and transistor T3 only will discharge Cell3.

On the other hand, the discharge path of Cell1 depends on the resistance of the load. If the load resistance is high compared to  $R_1 + R_{T1}$  then most of the discharge current will flow through power transistor T1. But, if the load resistance is low then some of the discharge current will flow through the load, making the balancing operation less efficient.

The equivalent discharge resistance across the cell being balanced is equated to be:

$$R_{\text{Discharge}} = \frac{(R_1 + R_{T1}) \times R_{\text{Load}}}{R_1 + R_{T1} + R_{\text{Load}}}$$

To decrease the discharge time requires a power transistor with very low on resistance and a minimum  $R_1$  resistance. The load resistance depends on the system and there is little control on that. It is preferred to have a load resistance that is higher than the  $R_1 + R_{T1}$  such that most of the discharge current will flow through the power transistor and not through the load. This is why balancing is more effective during an initial "overnight" conditioning cycle, where there is very little, if any load current.

A typical initial overnight conditioning time period is up to 18 hrs. If the cell balancing is performed during the charge phase, as shown in Figure 5, the charger delivers a current equal to  $I_{\text{charge}}$ , where  $I_{\text{charge}} = I'_{\text{charge}} + I_{\text{load}}$ . The actual current that charges the battery is  $I'_{\text{charge}}$  and its maximum

level is when the load resistance is disconnected. However, if the load resistance is active during the charge phase, some of the charge current will flow through the load. During the cell 1 balancing operation,  $I'_{\text{charge}} = I_1 + I_2$ . The magnitude of  $I_2$  with respect to  $I_1$  depends on the sum of the resistance of power transistor T1 and the resistor R1.

### "One Time" SOC Adjustment

The SOC adjustment consists primarily of a one time conditioning of the battery pack before its first use. Conditioning requires at least one complete discharge of the pack, followed by a complete charge. After this, small variations that accumulate due to soft shorts can be removed with a much less rigorous balancing routine during the charge time only.

The current required to balance the pack is at a maximum during the initial conditioning cycle. Typically the internal resistance of a 18650 Li-ion cell is around 100mΩ. One simple way to look at the adjustment is to assume Cell1 is fully charged and that it is 15% higher than Cell2 and Cell3, which are matched.

During the conditioning cycle, the load is removed and the Cell1 is discharged by opening the path  $R_1 + T1$ . With the cell at 4.20V, 100mA flows through a balancing resistor of 42Ω. The on resistance of the transistor is insignificant (usually less than 1Ω.) The power dissipation in the resistor is 0.42W.

$$\frac{4.20V}{0.100A} = (R_1 + R_{T1}) = 42\Omega$$

$$P_{\text{dissipation}} = IV = .100A \cdot 4.20V = .42W$$

If using a 2000mAh pack and a 3 hour discharge time during the conditioning cycle, the 300mAh removed from Cell1 corrects for the 15% imbalance.

If a larger capacity pack is used, then balancing either requires more current or more discharge/charge cycles. Assume the use of a 6000mAh battery pack, with the same 100mA balancing current. The pack is discharged over 3 hours, which corrects for 5% of the imbalance. Next, the pack is charged, again with the transistor T1 turned on. In this case, Cell1 receives 100mA less current than the other cells. If the charge time is also 3 hours, the other cells receive about 300mAh more charge than does Cell1, for a total of 10% discharge/charge correction.

Given enough time for the conditioning cycle, this process can be extended to multiple discharge/charge cycles. This allows both the ability to adjust for wider SOC differences and to make adjustments for lower balancing current (reduced power dissipation.)

Naturally, balancing can occur at intermediate stages of charge, rather than full discharge, but this would only decrease the total time available for balancing.

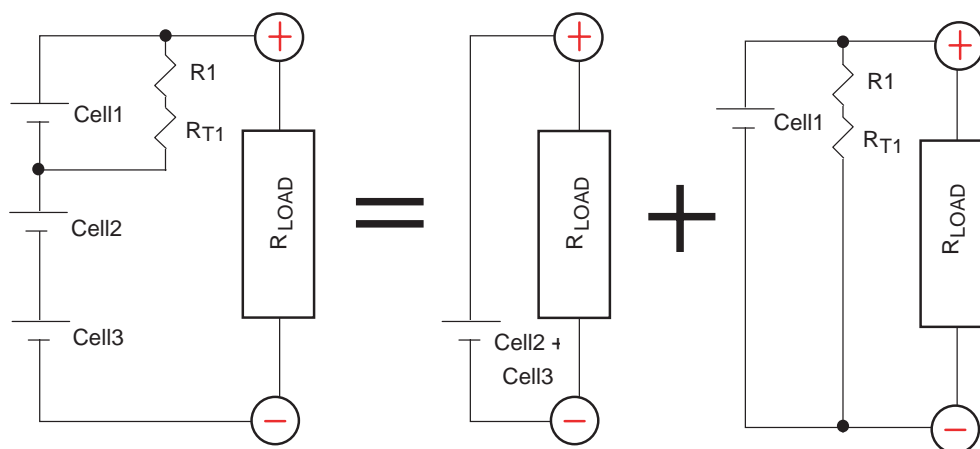

FIGURE 4.

### Issues With Cell Balancing Techniques

There are numerous issues with the current techniques to keep cells balanced.

#### Balancing cells during a discharge phase:

1. Balancing during the discharge phase dissipates power that is not utilized. However, when done during a conditioning cycle this power loss does not impact the operating time of the system. This is more a problem if cell balancing is attempted during discharge while the system is operating.
2. It takes too long to balance a cell during discharge. Because the discharge rate is dependent on the value of the load resistance, balancing during system operation is less effective.
3. To balance during discharge requires an external power transistor with low on resistance if balancing needs to be done in a reasonable time. This is not a significant issue because low on resistance transistors are common and called MOSFETs or FETs.
4. Fast balancing during discharge requires low  $\Omega$  resistor in series with the power transistor to reduce power dissipation of the power transistor. Without this current limiting resistor, the transistor would effectively short out the battery. With an FET on resistance of 100m $\Omega$  (not uncommon) and a cell voltage of 4V, the transistor would dissipate 160Watts – quickly turning the transistor into a “blown” fuse.
5. Using a low  $\Omega$  resistor requires a large wattage device. This takes board area and increases cost. In one of the examples, the resistor needs to dissipate .42W. In order to minimize the heat generated and the stress on the resistor, a 2W resistor should be used. Ideally, cell balancing would require less current, requiring lower wattage resistors. But this power dissipation can also be handled using multiple resistors located at places in the pack where heat dissipation is greatest.

#### Balancing cells during charge phase:

1. Measuring the cell voltage during charge is not accurate and can lead to premature cell balancing. This requires that the charging be stopped periodically, so cell voltages can be measured.
2. Voltage spikes on the output of the charger can result from voltage switching and inductive resonance of the charger. These unexpected conditions can affect cell balancing through inaccuracies in measurements and variations in cell balancing current.
3. Balancing during charge also requires an external power transistor with low on resistance to divert current from the cell to be balanced. This leads to the same limitations as balancing during discharge, however balancing during charge is usually to correct for soft shorts, so required balancing current is less.
4. Due to the low resistance of the unbalanced cell, it is not possible to divert all the charge current around the unbalanced cell. Therefore, some amount of current will flow through the unbalanced cell but at a lower rate than through the other balanced cells in the battery pack. This requires cell balancing to start at a lower voltage to allow enough time to balance the cells within the standard Li-ion cell safety limits.

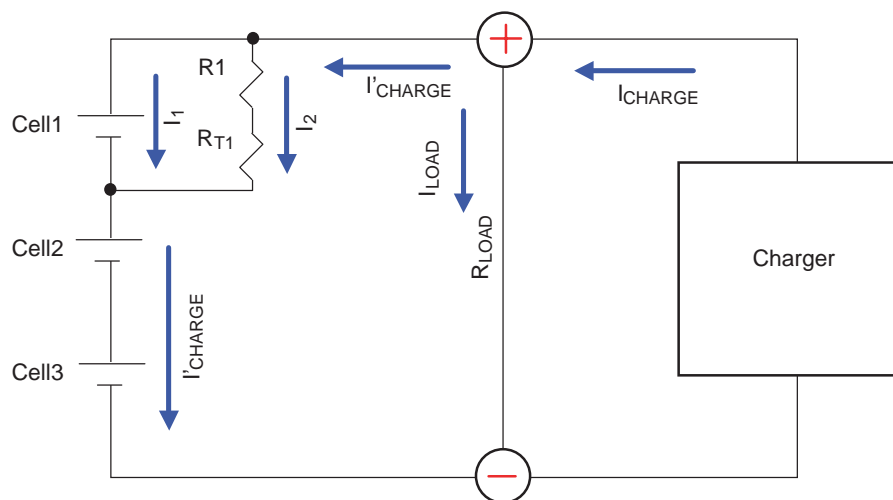

FIGURE 5.

### Recommendations for Cell Balancing

The recommended way to implement cell balancing is to perform balancing is to provide a conditioning cycle on initial pack charge that balances during discharge and charge. Subsequently, balancing is only performed during charging.

When balancing during charge, the controller in the battery pack controls the current applied from the charger, likely through management of the charge control FET in the pack. It is recommended that the charger be able to deliver a pulse of current for a relatively short duration. The battery pack voltage and cell voltages are measured during a rest time between the current pulses. If a mismatch is developed between the cells, then the balancing power transistor is turned on and the unbalanced cell will be charged with less current. During the next rest period the cells will be measured again and if balancing is reached the power transistor will be turned off.

The duration of the current pulse can vary. If the battery is fully discharged, the current charging period can last longer and the measurement period between current charging can be less frequent. As the battery voltage increases and the battery gets closer to the full charge limit, the current pulse duration decreases and the frequency of battery voltage measurement increases. If any cell in the battery pack reaches an over voltage level during charge time before the cells are balanced, then a period of discharge must take place by extending the rest period to allow the particular battery pack cells to stay in the safe zone. In this case several cycles of charge and discharge cycles should take place until all the cells are equalized.

Improving the control on the charger such that the current that the charger delivers can be increased or decreased is very important. If the temperature during charge exceeds a pre-assigned level, the battery pack can request less current from the charger to help reduce the temperature while still charging the battery but at a lower rate.

Measuring the voltage of each cell provides monitoring of the cell balancing operation. It is important that the load be constant during the monitoring period, so the current consumed by the battery pack does not change while the voltage for each cell is monitored.

Balancing the cells during discharge in a conditioning operation is a simpler process. The controller in the battery pack removes the load, by controlling the pack discharge FET. The controller then turns on the transistor across the cell with the highest voltage. When this voltage matches the others, the transistor is turned off. Trying to balance the cells during discharge while the system is operating is more difficult, because of varying loads. Changing loads affects the rate of balance and the accuracy of cell voltage and pack current measurements.

As described above, there are a number of factors that go into the cell balancing algorithm. One implementation of this algorithm was developed by PoweReady, Inc. in San Diego. In their implementation, PoweReady uses a microcontroller and the Intersil X3100 to monitor the individual cell voltages and controls the pack charge/discharge FETs and the cell balancing FETs. Since the microcontroller is flash-based, changes to the cell balancing algorithm are possible even after pack assembly. These changes can incorporate new balancing parameters or compensate for variations in the cell chemistry.

## Pack Balancing Electronics

In order to implement cell balancing, the battery pack needs a number of components. It must be able to:

- Accurately monitor the voltage on each cell independently. This requires differential amplifiers that can operate with a supply voltage of up to 20V, have an input differential range of between 2 and 4.5V and have an accuracy of better than 10mV.
- Determine the highest voltage cell and the voltage differential between all the cells. This requires a number of hardware comparators or a computer controlled comparison mechanism (A/D converter plus software algorithm.)
- Make decisions on the cell voltage differences and initiate cell balancing. This is either a microcontroller, or a hardware state machine.
- Control cell balancing FETs. These FETs are generally individual discrete components. The control signal needs to be able to provide gate voltages that range between 3V and 17V.

These components must be integrated as much as possible to avoid a significant increase in the cost of the battery pack electronics. The Intersil X3100 Safety/Monitor IC shows an example of one way of integrating these components. This device provides a level shifter and a monitor on each cell voltage. The monitors are differential op amps. An analog

multiplexer allows a microcontroller (with built-in A/D converter) to read each of the cell voltages. Through software on the IC, the pack can determine the balancing error and implement corrective actions. The X3100 also provides the FET drivers to eliminate the need to add level shifting circuits to drive high voltage from the 5V powered microcontroller.

## Conclusion

Cell balancing can increase the useable capacity of the Lilon systems when there is charge loss or capacity loss within a series string. Cell balancing then improves the life of the battery pack.

Adding cell balancing is now possible with new devices that integrate elements of the cell balancing control to reduce the cost. Devices like the X3100, from Intersil, integrate the voltage monitor circuits and FET control elements and allow an external microcontroller to evaluate the need for cell balancing. The microcontroller in the pack then uses level shifters to control the FETs according to the specific algorithm. Using an algorithm programmed into a flash-based microcontroller provides the ability to change the cell balancing operation even after pack assembly. This approach gives the battery pack designer the ability to use the latest cell technology and provides the flexibility to create a battery pack to meet the precise needs of the system.

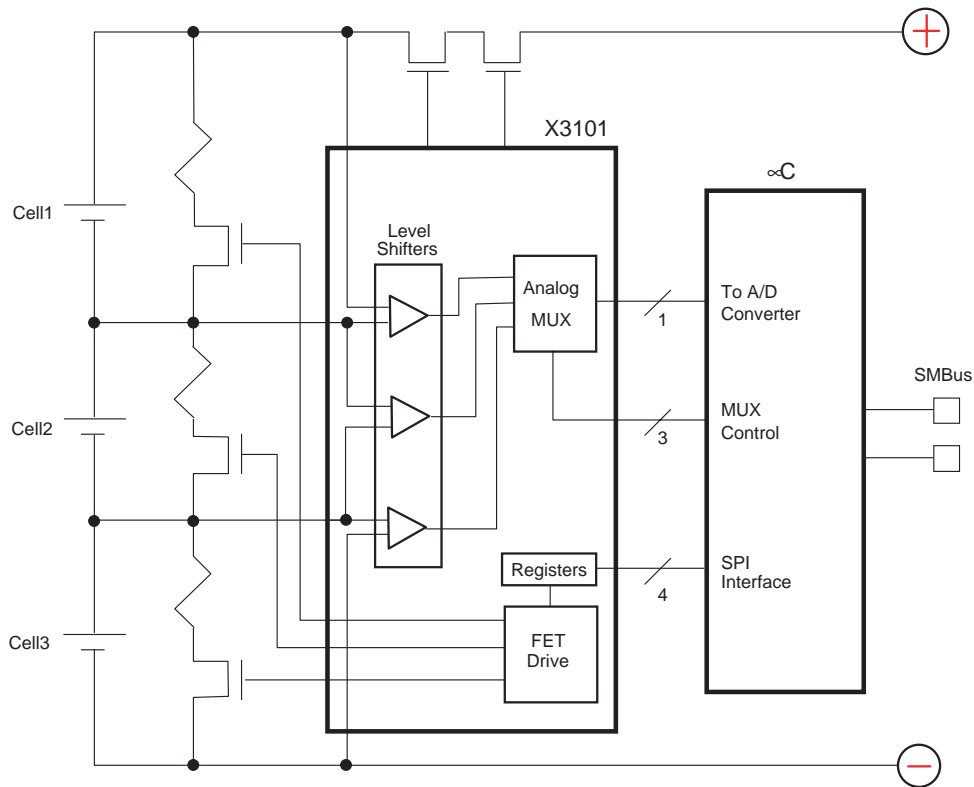

FIGURE 6.

Intersil Corporation reserves the right to make changes in circuit design, software and/or specifications at any time without notice. Accordingly, the reader is cautioned to verify that the Application Note or Technical Brief is current before proceeding.

For information regarding Intersil Corporation and its products, see [www.intersil.com](http://www.intersil.com)